

BROACHING TOOL

INSERTS

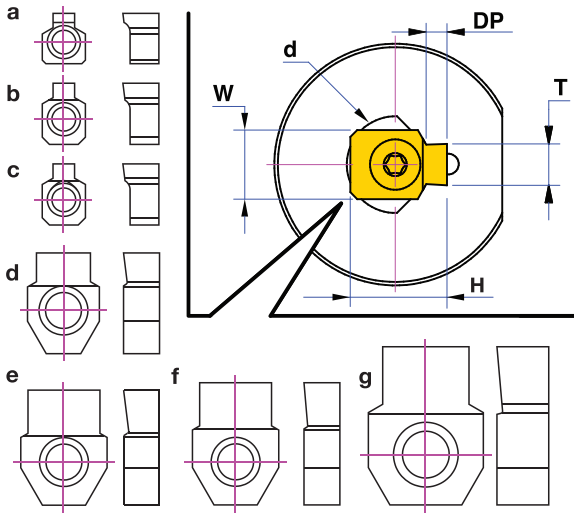

Insert dimensions

Order No.	W	H	Max. tooth T	Max. tooth DP	Min. Part Hole Pd
a YX0705-3	5	7	4.5	2	9
b YX0806-4	6	8.5	5.5	3	11
c YX1108-5	8	11.5	7.5	4	14
d YX1410-6	10	14	9.5	4.5	18
e YX1612-8	12	16	11.5	6	22
f YX1712-10	12	17	11.5	7	30
g YX2216-12	16	22	15.5	8	38
Tol					
Size					

HOLDERS

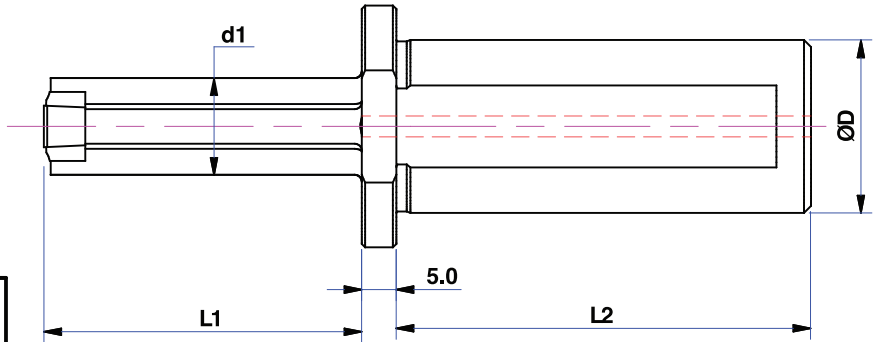

Holder dimensions

d1	L1	L2	ØD

PART SPECIFICATION

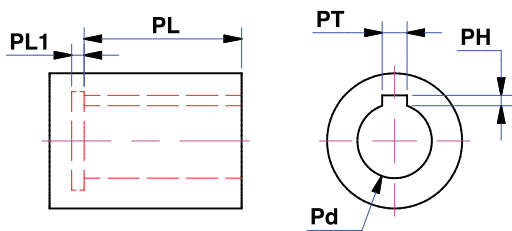

Part dimensions

	PL1	PL	PT	Pd	PH
Tol					
Size					

